

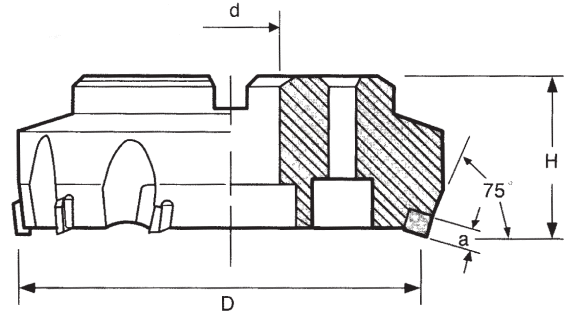

FACE Milling Cutter 75°

75°

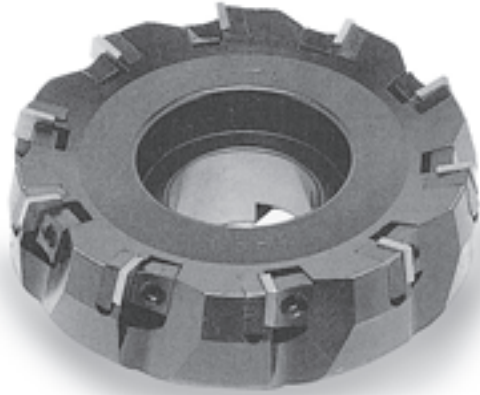

ORDER NO.	D	dø		H	BLADE	WEIGHT(kg)		CODE NO.
		INCH	METRIC			INCH	METRIC	
FP-3	80	25.4	27	50	5	2	2	6001-090
FP-4	100	31.75	32	55	6	3.1	3.4	6001-091
FP-5	125	38.1	40	60	8	5.3	5.1	6001-092
FP-6	160	50.8	40	60	10	6.5	6.8	6001-093
FP-8	200	47.625	60	60	12	9.6	9.6	6001-094
FP-10	250	47.625	60	60	16	17.1		6001-095
FP-12	300	47.625	60	60	20	29.3		6001-096

INSERT	PARTS				
SPUN-120308					
SPKM-1203EDR					
	SCR-CL5/16	CL-S	SCR-ST-S4	ST-S	WRN-M4T



FACE Milling Cutter 90°

90°

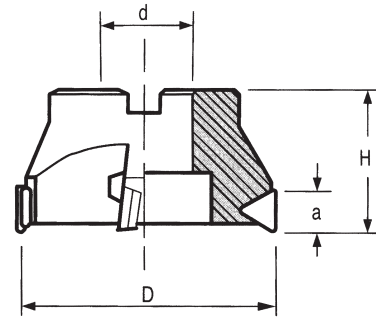
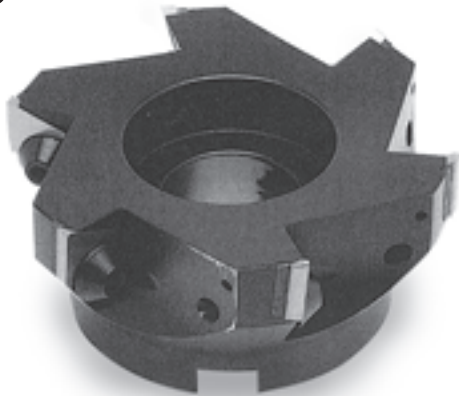

ORDER NO.	D	dø		H	a	BLADE	WEIGHT(KG)	INSERT						CODE NO.
		INCH	METRIC											
TP-63	63	25.4	27	50	22	3	1.1	TPMN 2204	ST-T	SCR-W5/16	WRN-M5L	SCR-ST-T4	6001-110	
TP-80	80	25.4	27	50	22	4	1.5		ST-T	SCR-W5/16	WRN-M5L	SCR-ST-T4	6001-111	
TP-100	100	31.75	32	55	22	5	2.2		ST-T	SCR-W5/16	WRN-M5L	SCR-ST-T4	6001-112	
TP-125	125	38.1	40	60	22	6	3.5		ST-T	SCR-W5/16	WRN-M5L	SCR-ST-T4	6001-113	
TP-160	160	50.8	40	60	22	7	5.9		TPKN 2204PPR	ST-T	SCR-W5/16	WRN-M5L	SCR-ST-T4	6001-114
TP-200	200	47.625	60	60	22	8	8.1			ST-T	SCR-W5/16	WRN-M5L	SCR-ST-T4	6001-115
TP-250	250	47.625	60	60	22	9	15.9			ST-T	SCR-W5/16	WRN-M5L	SCR-ST-T4	6001-116
TP-300	300	47.625	60	60	22	10	28			ST-T	SCR-W5/16	WRN-M5L	SCR-ST-T4	6001-117