

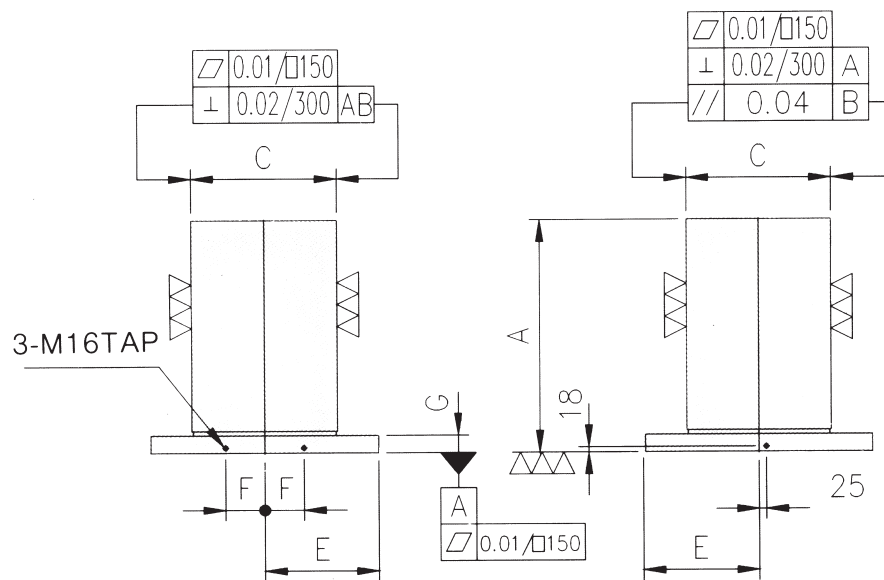

M/C Clamping Cube

- Material/Finish:
Material:FC300(JIS)/GG30(DIN)
Heat treated (Normalized)
- Application:Good for horizontal M/C
- Features:Free to finish an actual required hole pattern for your special jig.
- eye bolt included.

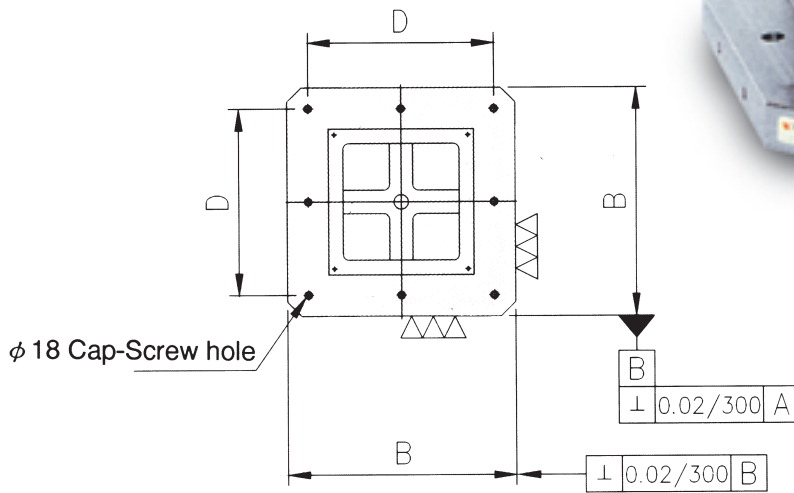
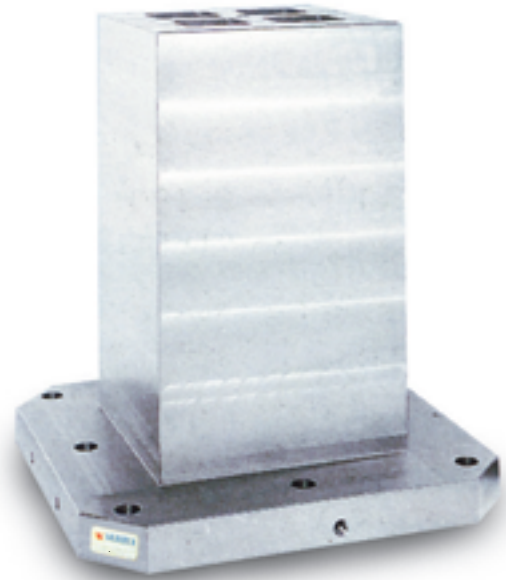

SPECIAL DESIGN WELCOME

ORDER NO.	A	B	C	D	E	F	G	No. of Mounting holes	kg	CODE.NO.
BP07-10	500	400	250	320	200	55	50	4	175	4007-020
BP07-20	600	500	300	400	250	75	50	8	240	4007-021
BP07-30	700	630	350	500	315	100	50	8	390	4007-022
BP07-40	800	800	500	640	400	135	50	8	745	4007-023